



Vehicle History Report™

2015 JEEP WRANGLER SPORT

VIN: 1C4AJWAG3FL604651
UTILITY (BLAZER, JIMMY, SCOUT, ETC.)
3.6L V6 F DOHC 24V
GASOLINE
REAR WHEEL DRIVE W/ 4X4
Original Window Sticker



Branded Titles: Rebuilt, Salvage



10 Service history records



At least 1 open recall



2 Previous owners



Personal vehicle



69,641 Last reported odometer reading

This CARFAX Vehicle History Report is based only on information supplied to CARFAX and available as of 2/24/24 at 4:43:08 PM (CST). Other information about this vehicle, including problems, may not have been reported to CARFAX. Use this report as one important tool, along with a vehicle inspection and test drive, to make a better decision about your next used car.



Ownership History

The number of owners is estimated

	Owner 1	Owner 2
Year purchased	2015	2021
Type of owner	Personal	Personal
Estimated length of ownership	2 yrs. 6 mo.	2 yrs. 2 mo.
Owned in the following states/provinces	See Details	California, Utah
Estimated miles driven per year	12,460/yr	11,607/yr
Last reported odometer reading	47,508	69,641



Title History

	Owner 1	Owner 2
Damage Brands Salvage Junk Rebuilt Fire Flood Hail Lemon	Alert! Problem Found	Alert! Problem Found
Odometer Brands Not Actual Mileage Exceeds Mechanical Limits	No Problem	No Problem



ALERT! - Severe problems were reported by a state Department of Motor Vehicles (DMV). This vehicle does not qualify for the CARFAX Buyback Guarantee.

CARFAX Additional History Not all accidents / issues are reported to CARFAX	Owner 1	Owner 2
Total Loss Total Loss Reported: 11/02/2017.	Total Loss Reported	No New Issues Reported
Structural Damage CARFAX recommends that you have this vehicle inspected by a collision repair specialist.	✓ No Issues Reported	✓ No Issues Reported
Airbag Deployment Airbag deployment reported: 08/10/2017.	Airbag Deployment	No New Issues Reported
Odometer Check No indication of an odometer rollback.	✓ No Issues Indicated	✓ No Issues Indicated
Accident / Damage DMV title problems reported. Accident reported: 08/10/2017.	Severe Damage	Severe Damage
Manufacturer Recall At least 1 manufacturer recall requires repair.	Recall Reported	No New Recalls Reported
Basic Warranty Original manufacturer warranty likely voided by manufacturer.	Warranty Voided	Warranty Voided

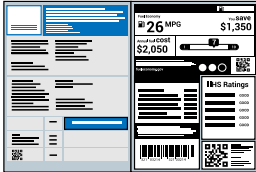

Detailed History

 Owner 1 Purchased: 2015	Personal Vehicle 12,460 mi/yr		
Date	Mileage	Source	Comments
Not Reported		FCA	Vehicle manufactured and shipped to original dealer  Original Window Sticker
12/29/2014		Team Chrysler Jeep Dodge RAM of Morganton Morganton, NC 828-212-6395	Vehicle offered for sale

★ 4.8 / 5.0

19 Verified Reviews

♥ 29 Customer Favorites

12/31/2014 14

Team Chrysler Jeep
Dodge RAM of
Morganton
Morganton, NC
828-212-6395



Vehicle serviced

- Pre-delivery inspection completed
- Safety inspection performed

★ 4.8 / 5.0

19 Verified Reviews

♥ 29 Customer Favorites

02/21/2015 68

Steve White Motors
Hickory, NC
828-464-3458

Vehicle sold

★ 4.8 / 5.0

169 Verified Reviews

♥ 118 Customer Favorites

03/16/2015

North Carolina
Motor Vehicle Dept.
Asheville, NC

Title or registration issued

- First owner reported
- Titled or registered as personal vehicle
- Loan or lien reported

04/28/2015 3,182

Skyland Automotive
Asheville, NC
828-667-5213



Vehicle serviced

- Maintenance inspection completed
- Oil and filter changed

★ 4.5 / 5.0

96 Verified Reviews

05/08/2015 5,313

Skyland Automotive
Asheville, NC
828-667-5213



Vehicle serviced

★ 4.5 / 5.0

96 Verified Reviews

07/31/2015 8,724

Skyland Automotive
Asheville, NC
828-667-5213



Vehicle serviced

- Maintenance inspection completed
- Oil and filter changed
- Tires rotated

★ 4.5 / 5.0

96 Verified Reviews

02/16/2016 14,074

Skyland Automotive
Asheville, NC
828-667-5213



Vehicle serviced

- Maintenance inspection completed
- Oil and filter changed

★ 4.5 / 5.0

96 Verified Reviews

03/08/2016 14,455

Valvoline Instant Oil
Change
Asheville, NC



Vehicle serviced

- Safety inspection performed

828-277-7976

★ 4.6 / 5.0

174 Verified Reviews

♥ 132 Customer Favorites

03/11/2016

North Carolina
Motor Vehicle Dept.
Asheville, NC

Registration issued or renewed

- Loan or lien reported

08/01/2016 18,185

Mississippi
Motor Vehicle Dept.
Hattiesburg, MS

Vehicle purchase reported

- Title issued or updated
- Loan or lien reported
- Registration updated when owner moved the vehicle to a new location
- Vehicle color noted as White

09/15/2016 19,527

Pine Belt Chrysler Dodge
Jeep RAM
Hattiesburg, MS
601-544-2430



Vehicle serviced

- Oil and filter changed

★ 4.4 / 5.0

95 Verified Reviews

♥ 1,618 Customer Favorites

08/10/2017

Damage Report



Accident reported: moderate damage with another motor vehicle

- Damage to right front
- Damage to front
- Damage to right rear
- Vehicle towed
- Front airbag deployed
CARFAX Airbag Tips

Damage Severity Scale







Damage Location

FRONT

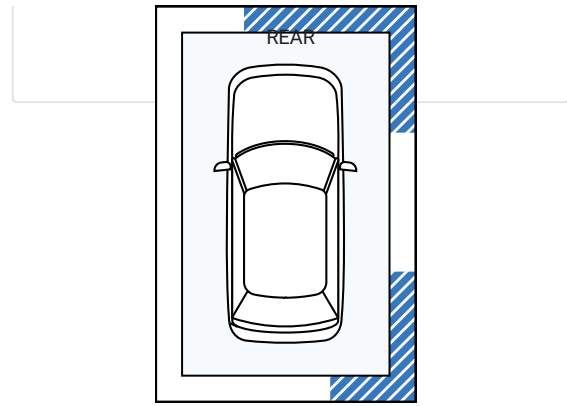
LEFT

RIGHT





10/02/2017	Mississippi Motor Vehicle Dept.	Vehicle purchase reported
11/02/2017	Damage Report	 TOTAL LOSS VEHICLE
		<div style="border: 1px solid blue; padding: 5px;"> <p>There are many reasons an insurance company will declare a vehicle a total loss. Have this vehicle inspected by a qualified technician before you buy. Learn More</p> </div>
11/02/2017	Mississippi Motor Vehicle Dept.	Title or registration issued to insurance company
11/02/2017	Mississippi Motor Vehicle Dept. Moss Point, MS	 SALVAGE TITLE/CERTIFICATE ISSUED - Vehicle color noted as White
01/15/2019	FCA US LLC	Manufacturer Safety recall issued - NHTSA #19V-018 - Recall #V01 PASSENGER AIRBAG INFLATOR - Status: Remedy available Click here for a copy of the owner letter for this Recall or call 1- 800-853-1403 if you have any questions or need additional information on this recall.  Learn more about this recall

Description: Some of the above vehicles may contain propellant that degraded after prolonged exposure to high absolute humidity, high temperatures and high temperature cycling. Activation of an inflator with degraded propellant, in a vehicle crash where the PAB is designed to deploy, may result in an inflator explosion.

An inflator explosion may cause metal fragments to pass through the air bag and into the vehicle interior at high speed, which may result in injury or death to vehicle occupants.

Remedy: Replace the PAB inflator





01/14/2020	46,295	Master Muffler And Brake Sandy, UT 801-566-0442 ★ 4.9 / 5.0 56 Verified Reviews ♥ 18 Customer Favorites		Vehicle serviced
05/26/2021	46,538	Utah Motor Vehicle Dept.		Vehicle purchase reported
08/26/2021	46,815	Autolocity Motors Ogden, UT ★ 4.4 / 5.0 5 Verified Reviews		Vehicle offered for sale
11/18/2021		Utah Motor Vehicle Dept. Ogden, UT		Dealer took title of this vehicle while it was in inventory - SALVAGE TITLE/CERTIFICATE ISSUED - REBUILT TITLE ISSUED - Vehicle color noted as White
12/03/2021	47,508	California Inspection Station		Passed emissions inspection



Owner 2

Purchased: 2021

Personal Vehicle
11,607 mi/yr

Date	Mileage	Source		Comments
12/13/2021		California Motor Vehicle Dept. San Francisco, CA		New owner reported - REBUILT TITLE ISSUED
12/24/2021		Utah Motor Vehicle Dept. Ogden, UT		Dealer took title of this vehicle while it was in inventory - SALVAGE TITLE/CERTIFICATE ISSUED - REBUILT TITLE ISSUED - Vehicle color noted as White
05/23/2022	50,592	The Smog Shop San Francisco, CA 415-863-4110 ★ 4.9 / 5.0 69 Verified Reviews ♥ 3 Customer Favorites		Vehicle serviced
06/10/2022		Service Facility		Vehicle reconditioned

01/12/2024 69,641 California
Inspection Station

Passed emissions inspection

Have Questions? Please visit our Help Center at www.carfax.com.



Glossary

Accident Indicator

CARFAX receives information about accidents in all 50 states, the District of Columbia and Canada.

Not every accident is reported to CARFAX. As details about the accident become available, those additional details are added to the CARFAX Vehicle History Report. CARFAX recommends that you have this vehicle inspected by a qualified mechanic.

- According to the National Safety Council, Injury Facts, 2021 edition, 5% of the 276 million registered vehicles in the U.S. were involved in an accident in 2019. Over 77% of these were considered minor or moderate.
- This CARFAX Vehicle History Report is based only on information supplied to CARFAX and available as of 2/24/24 at 4:43:08 PM (CST). Other information about this vehicle, including problems, may not have been reported to CARFAX. Use this report as one important tool, along with a vehicle inspection and test drive, to make a better decision about your next used car.

Airbag Deployment

Occurs when the driver, passenger or side airbag has been used or deployed during a crash or other incident. If an airbag has been deployed, it must be replaced by a qualified technician. Have this car inspected by a mechanic prior to purchase.

Damage Indicator

Damage can be a result of many different types of events. Examples include contact with objects (other cars, trees, traffic signs, road debris, etc), vandalism, or weather-related events. Not every damage event is reported to CARFAX. As details about the damage event become available, those additional details are added to the CARFAX Vehicle History Report. CARFAX recommends that you have this vehicle inspected by a qualified mechanic.

- This CARFAX Vehicle History Report is based only on information supplied to CARFAX and available as of 2/24/24 at 4:43:08 PM (CST). Other information about this vehicle, including problems, may not have been reported to CARFAX. Use this report as one important tool, along with a vehicle inspection and test drive, to make a better decision about your next used car.

Damage Severity

Damage events result in one of the following severity levels:

- Minor: Generally, minor damage is cosmetic (including dents or scratches), may only require reconditioning, and typically does not compromise a vehicle's operation and/or safety.
- Moderate: Moderate damage may affect multiple components of the vehicle and may impair the vehicle's operation and/or safety.
- Severe: Severe damage usually affects multiple components of the vehicle and is likely to compromise the vehicle's operation and/or safety.

CARFAX recommends getting a pre-purchase inspection at a certified collision repair facility.

First Owner

When the first owner(s) obtains a title from a Department of Motor Vehicles as proof of ownership.

Manufacturer Recall

Automobile manufacturers issue recall notices to inform vehicle owners of a safety defect or failure to meet minimum federal safety or emissions standards. Manufacturer recalls are repaired at no cost to the customer.

New Owner Reported

When a vehicle is sold to a new owner, the Title must be transferred to the new owner(s) at a Department of Motor Vehicles.

Ownership History

CARFAX defines an owner as an individual or business that possesses and uses a vehicle. Not all title transactions represent changes in ownership. To provide estimated number of owners, CARFAX proprietary technology analyzes all the events in a vehicle history. Estimated ownership is available for vehicles manufactured after 1991 and titled solely in the US including Puerto Rico. Dealers sometimes opt to take ownership of a vehicle and are required to in the following states: Maine, Massachusetts, New Jersey, Ohio, Oklahoma, Pennsylvania and South Dakota. Please consider this as you review a vehicle's estimated ownership history.

Rebuilt/Reconstructed Title

A Rebuilt/Reconstructed vehicle is a salvage vehicle that has been repaired and restored to operation. These vehicles are often severely damaged before they are rebuilt and refurbished parts are typically used during reconstruction. In most states, an inspection of the vehicle is required before the vehicle is allowed to return to the road.

Salvage Title

A Salvage Title is issued on a vehicle damaged to the extent that the cost of repairing the vehicle exceeds approximately 75% of its pre-damage value. This damage threshold may vary by state. Some states treat Junk titles the same as Salvage but the majority use this title to indicate that a vehicle is not road worthy and cannot be titled again in that state. The following eleven states also use Salvage titles to identify stolen vehicles - AZ, FL, GA, IL, MD, MN, NJ, NM, NY, OK and OR.

Title Issued

A state issues a title to provide a vehicle owner with proof of ownership. Each title has a unique number. Each title or registration record on a CARFAX report does not necessarily indicate a change in ownership. In Canada, a registration and bill of sale are used as proof of ownership.

Total Loss Vehicle

An insurance or fleet company declares a vehicle a total loss when a claim exceeds approximately 75% of its pre-damage value or if the vehicle is stolen and not recovered. This damage threshold varies by company. These companies typically take possession and obtain the title. Not all total loss vehicles result in a DMV-reported branded title. This may occur when an insurance company's definition of a total loss is different than the state DMV's definition for a branded title or when the owner of the vehicle is a self-insured company, like a fleet or rental company.

Follow Us:  facebook.com/CARFAX  [@CARFAXinc](https://twitter.com/CARFAXinc)  **About CARFAX**

CARFAX DEPENDS ON ITS SOURCES FOR THE ACCURACY AND RELIABILITY OF ITS INFORMATION. THEREFORE, NO RESPONSIBILITY IS ASSUMED BY CARFAX OR ITS AGENTS FOR ERRORS OR OMISSIONS IN THIS REPORT. CARFAX FURTHER EXPRESSLY DISCLAIMS ALL WARRANTIES, EXPRESS OR IMPLIED, INCLUDING ANY IMPLIED WARRANTIES OF MERCHANTABILITY OR FITNESS FOR A PARTICULAR PURPOSE.

© 2024 CARFAX, Inc., part of S&P Global. All rights reserved.
2/24/24 4:43:08 PM (CST)